

POOL LIFT METALU 3800

BATTERY-POWERED POOL LIFT



METALU WARRANTY

3 YEARS The lift

5 YEARS All spare parts

INSTALLATION



Table of contents

Installation of the lift	3
1. Anchor dimensions.....	3
2. Pre-installation	4
3. Installation of the lift	5
4. Assembly of the lift.....	10
5. Transport of the lift	14



Installation of the lift

1. Anchor dimensions

The METALU S-3800 and S-3800/1 model includes 8 anchor bolts. **These are cylindrical anchors with a length of 90 mm and an external diameter of 12 mm.**

The distances between the anchors (in millimetres) are shown in the following image:

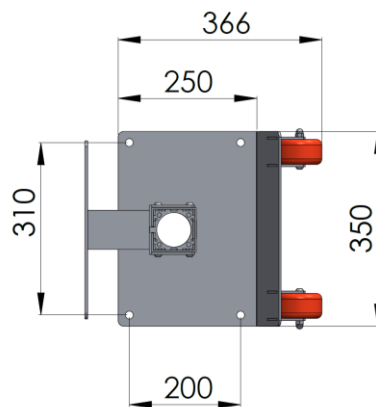

The distances between the 4 anchor bolts of the base plate to the wall (in millimetres) are shown in the following image:

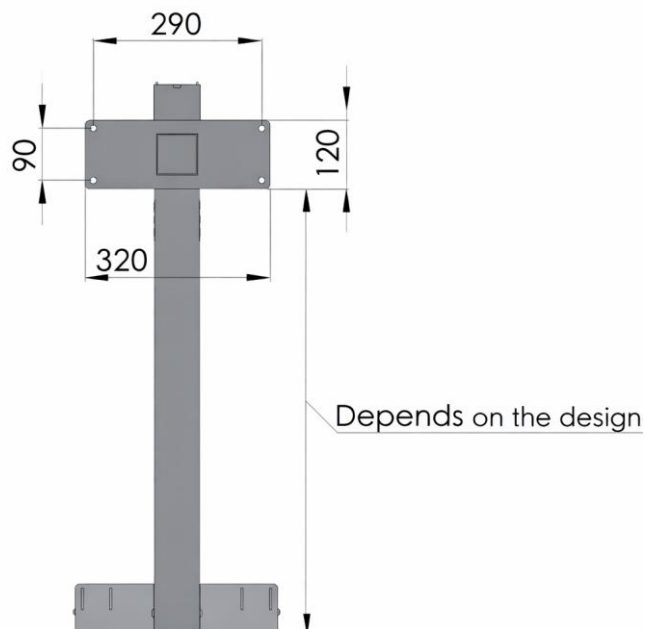



2. Pre-installation

Before installing the METALU S-3800 or S-3800/1 lift, the following points must be considered:

- When selecting the installation area of the lift, take into account the **Spanish Technical Building Code (CTE)**, as well as any regulations applicable in each autonomous community.
- Carefully choose the location of the lift. It is recommended to install the lift where the pool basin **has an adequate depth so that, if the user requires assistance, another person can stand safely in the pool.**
- The lift must have an operating radius **free of obstacles**. The dimension of this radius depends on the customised design of each lift.
- Verify that the lift is not installed over the skimmer, pipes, return inlets or any other external component that may affect the normal operation of any element.
- Connection to the supplementary equipotential bonding network is mandatory **for all lifts**.

Public or communal pools must comply with the regulations of each autonomous community when **carrying out the connection to the supplementary equipotential** bonding network available in the pool, in accordance with the complementary technical instructions of the Low Voltage Electrotechnical Regulation ITC-BT-31.

The equipotential bonding connection for the METALU S-3800 and S-3800/1 models is located at the base of the lift, and can therefore be connected to any of its 8 anchor bolts.



3. Installation of the lift

For the installation of the METALU S-3800 and S-3800/1 lift models, the following tools and materials are required:

- Hammer drill.
- 14 mm drill bit.
- Standard tools:
 - Open-ended spanners 12–13.
 - Pencil or pen for marking drill holes.
- Epoxy chemical anchor.
- Application gun for epoxy chemical anchor.

For installation, the regulations established by each autonomous community must be taken into account.

There are two anchoring options for the METALU S-3800 and S-3800/1 models:

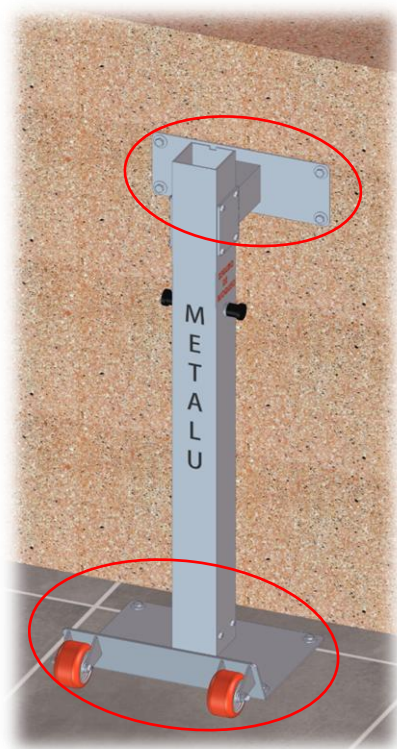

Wall and ground anchoring

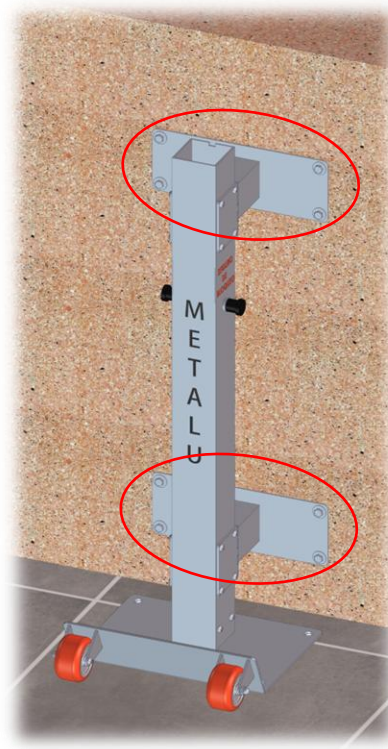

Double wall anchoring



For both installation configurations, the same steps are followed, paying special attention to the position of the anchor bolts. The wall and ground installation is shown below:

Step 1. Position the lift in the desired location and mark the 8 drill holes for the anchor bolts in the appropriate positions (ground or wall). The lift base must be perfectly plumb (vertical).

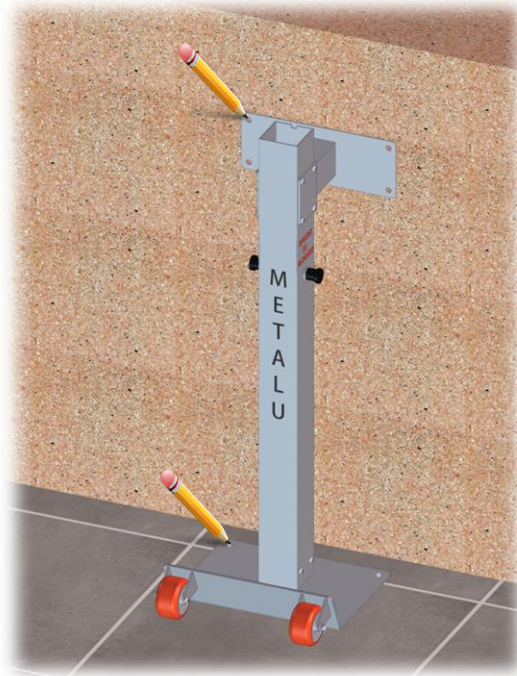

Step 2. Drill the previously marked points using a drill with a 14 mm drill bit. For safety reasons, it is recommended that no bathers are present while drilling.



Thoroughly clean the drilling dust using air or water if necessary.



Step 3. Fill half of each hole with epoxy chemical anchor.

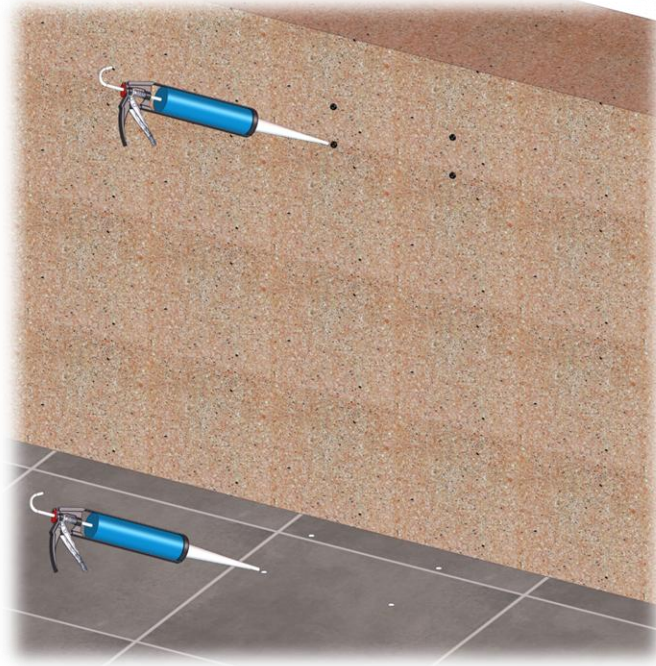

Step 4. Insert the 8 anchor bolts, ensuring that there are no obstructions in the holes. If necessary, reapply epoxy chemical anchor along the sides of the holes to prevent air voids from forming.

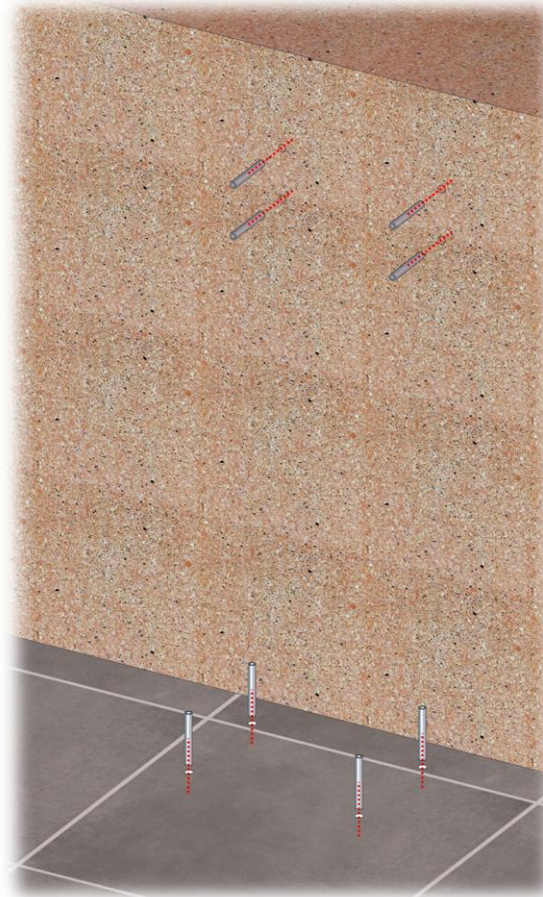



Step 5. Ensure that there are no obstructions in the holes and that they are **flush with the ground, neither protruding nor recessed**. Take into account that the lift base must be perfectly plumb (vertical).

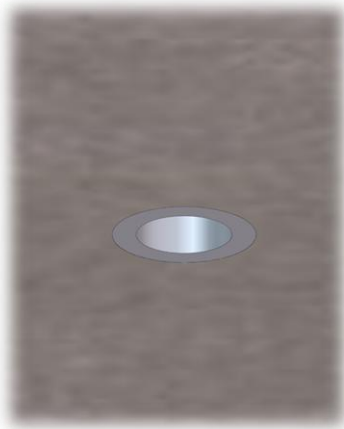

Correct position:
Flush with the ground

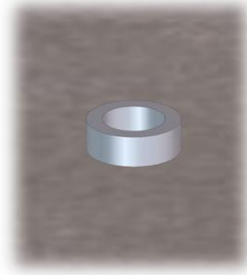

Incorrect position:
Protruding



Incorrect position:
Recessed

Step 6. Position the lift and fasten the corresponding bolts into the anchor bolts without fully tightening them. Wait for the epoxy chemical anchor to cure according to the manufacturer's specifications.

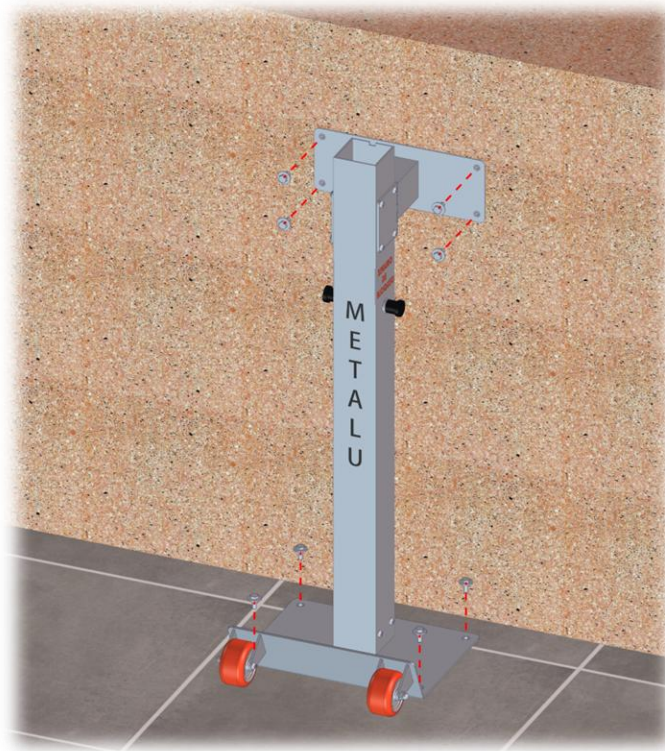

Step 7. Once the epoxy chemical anchor has cured, fully tighten the bolts of the anchor system.



The final result of the anchor installation is shown in the following figure:

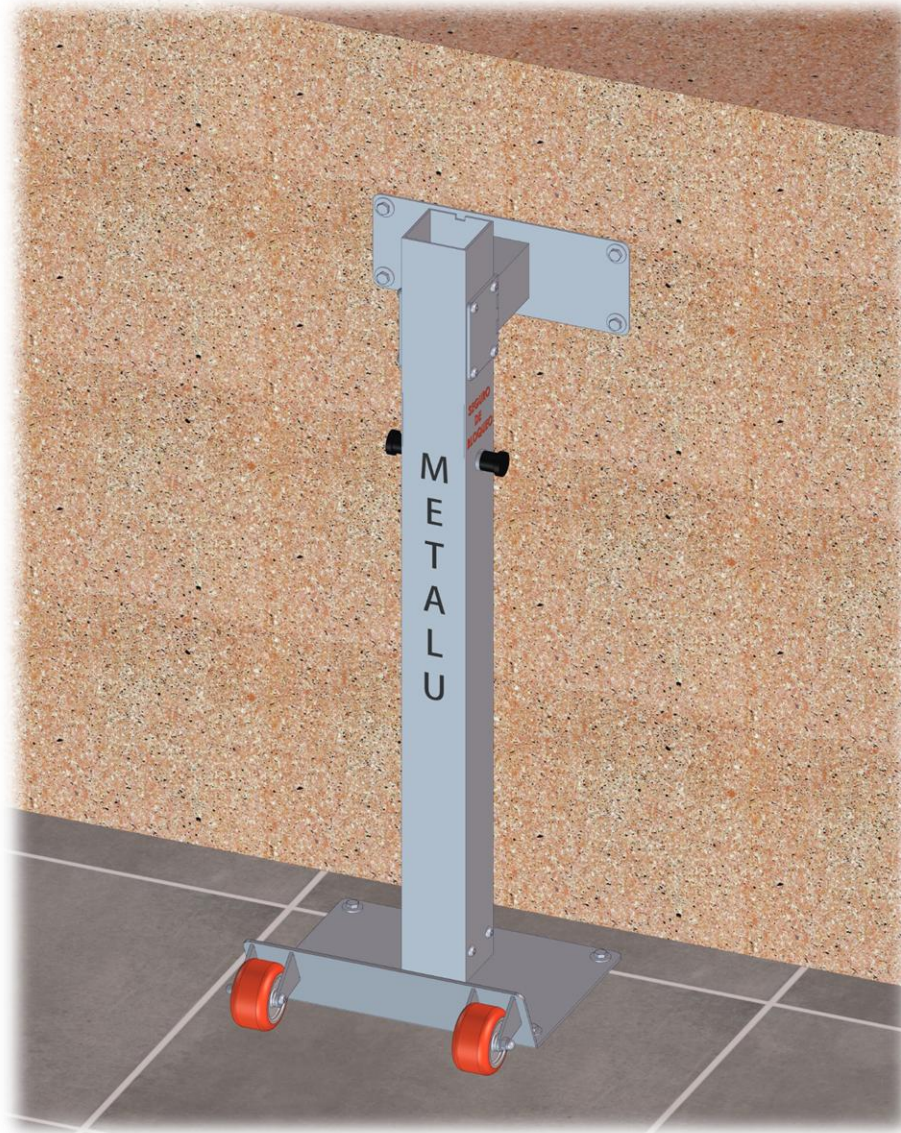

4. Assembly of the lift

The step-by-step assembly of the S-3800 and S-3800/1 lift is explained below in detail.

The steps to follow are as follows:

1. Fit the fixed structure and the moving structure together in the only possible position, aligning the notch of both structures. Then secure the locking mechanism or positioner of the lift base.

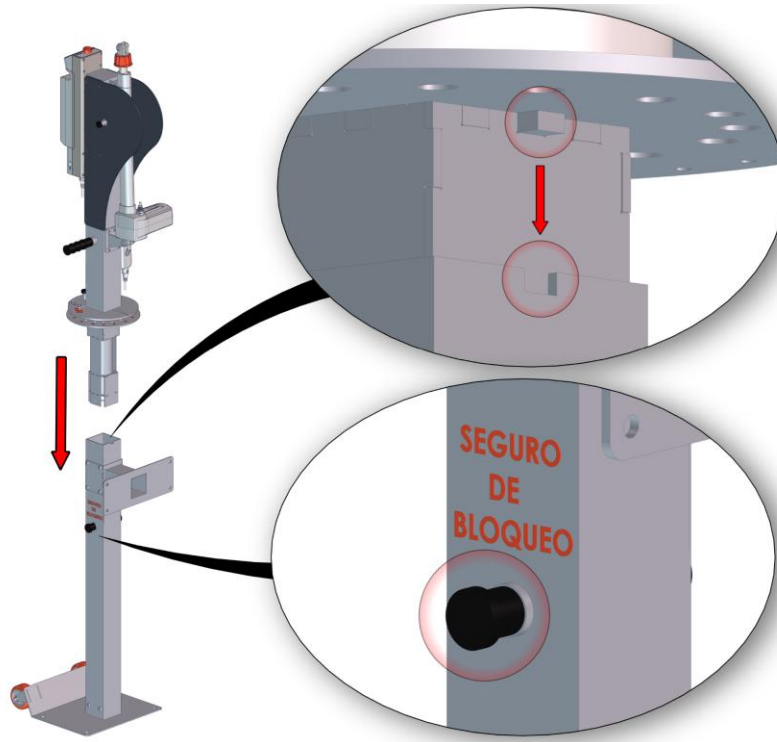

2. Release the electric actuator from the metal sling and let it rest on the lift.

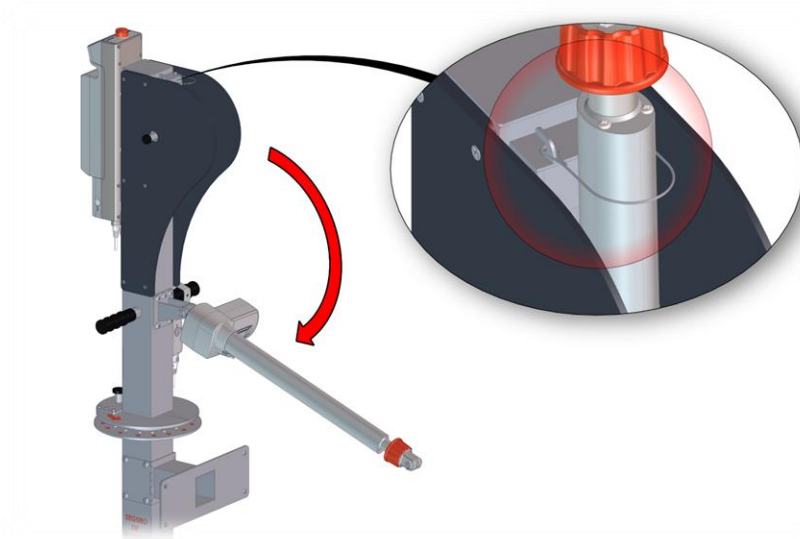

3. Insert the arms into their corresponding slots and secure them with the positioners. To do this, pull the positioners and rotate them a quarter turn.
WARNING! Ensure that the positioners are correctly inserted and that the arms are firmly secured, carrying out any necessary checks.

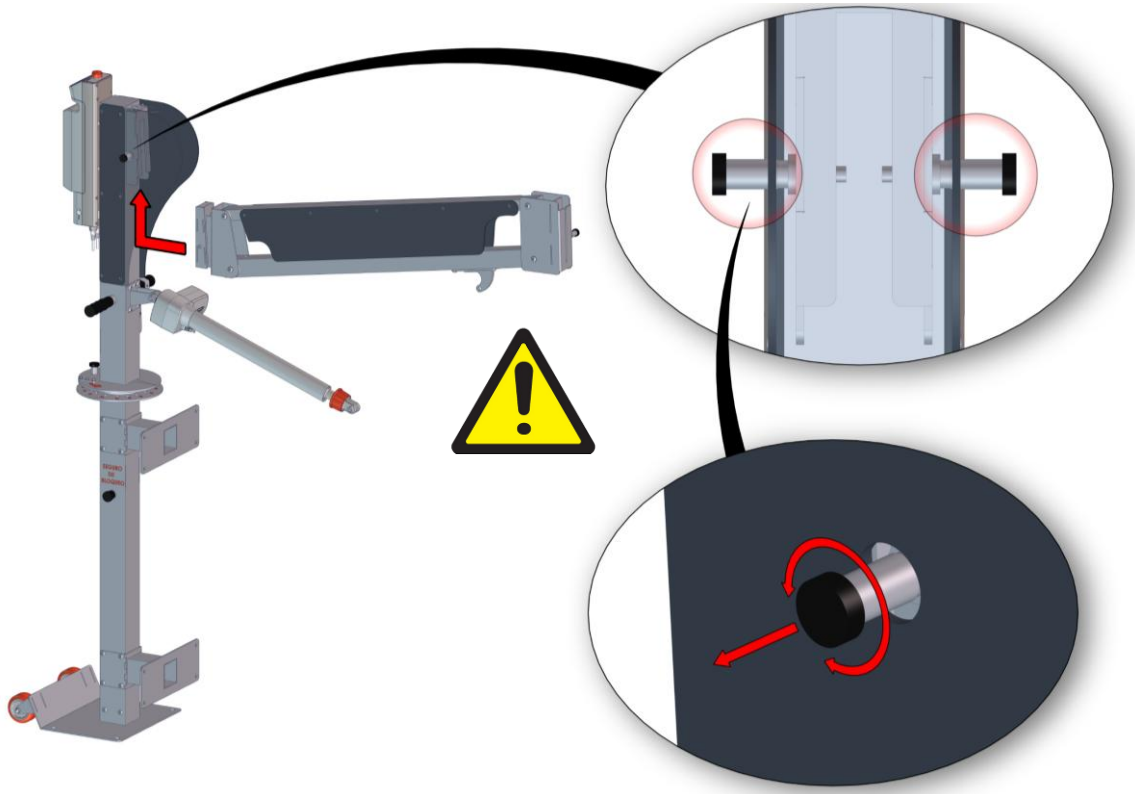

4. Fix the electric actuator to the lift arms using the pin.

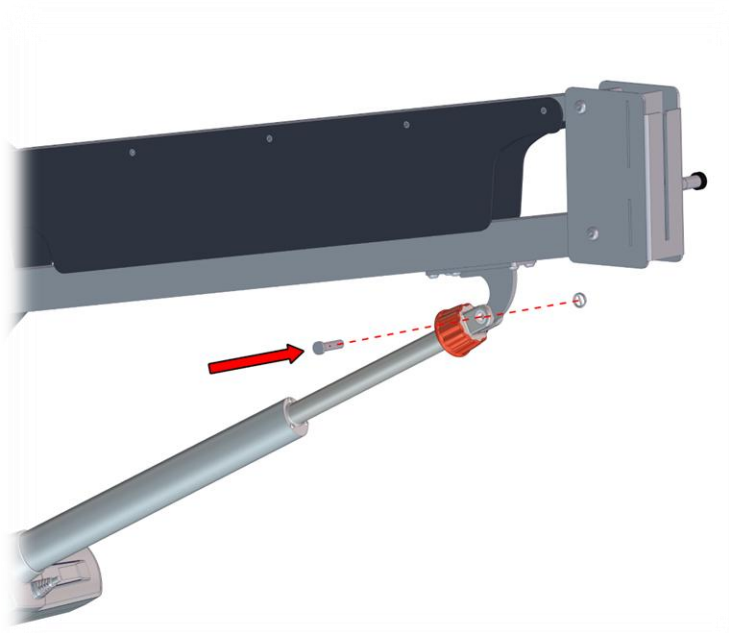



5. Assemble the seat in the corresponding slot of the arm.



6. Finally, secure the seat with the safety positioner. To do this, pull the positioner and rotate it a quarter turn.
WARNING! Ensure that the positioners are correctly inserted and that the arms are firmly secured, carrying out any necessary checks.

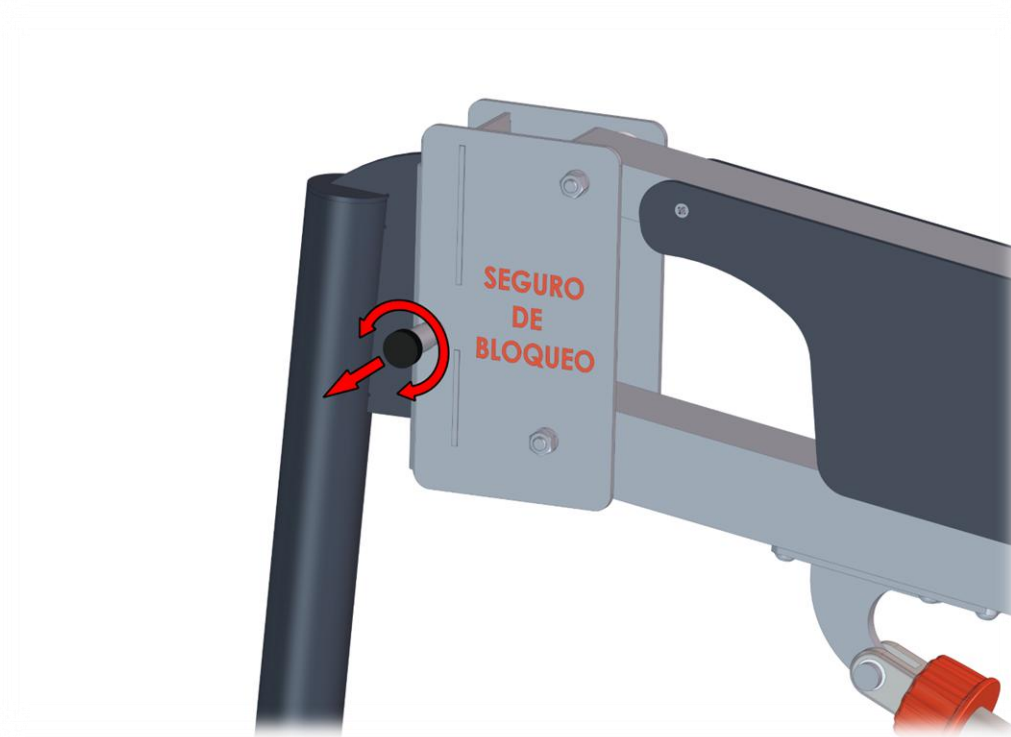



The final assembly of the lift should be similar to the following image:



To **disassemble the lift**, follow the above steps in reverse order.

5. Transport of the lift

The lift must always be transported with the arms disassembled. The following image shows the correct way to transport the lift:

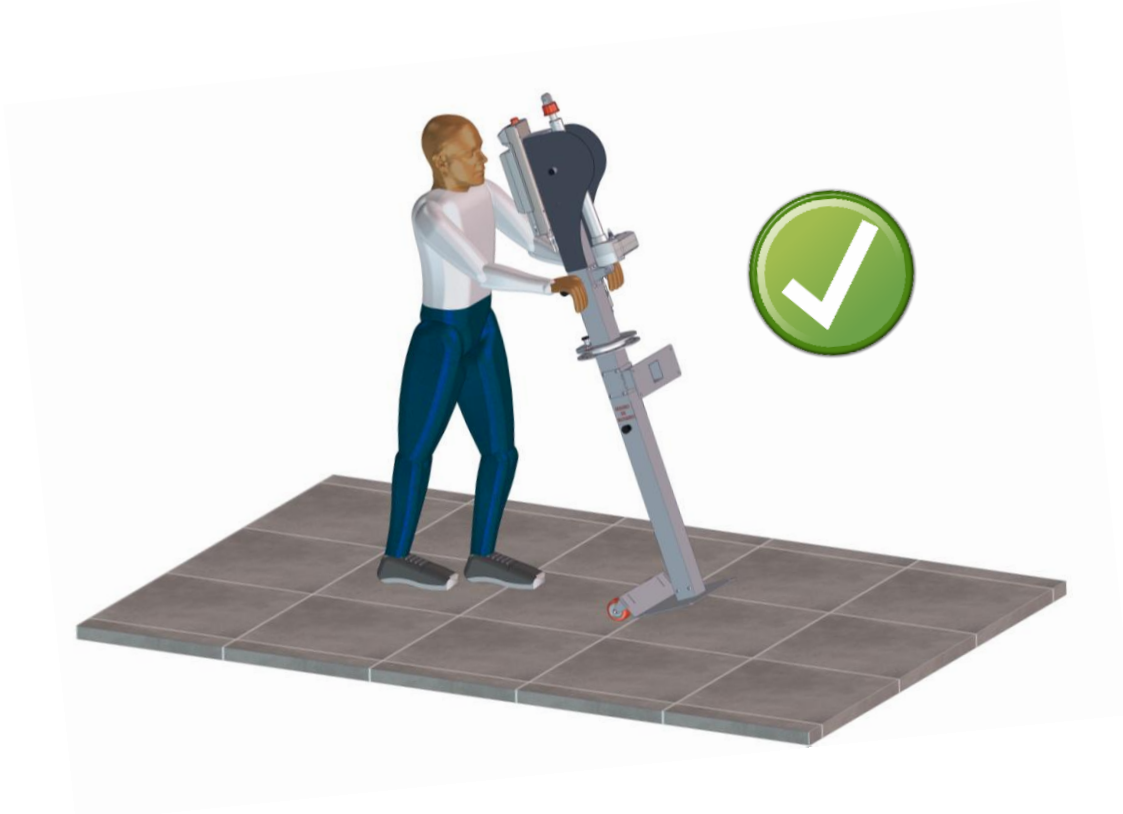

The lift **must not be transported** with the arm or the seat assembled:

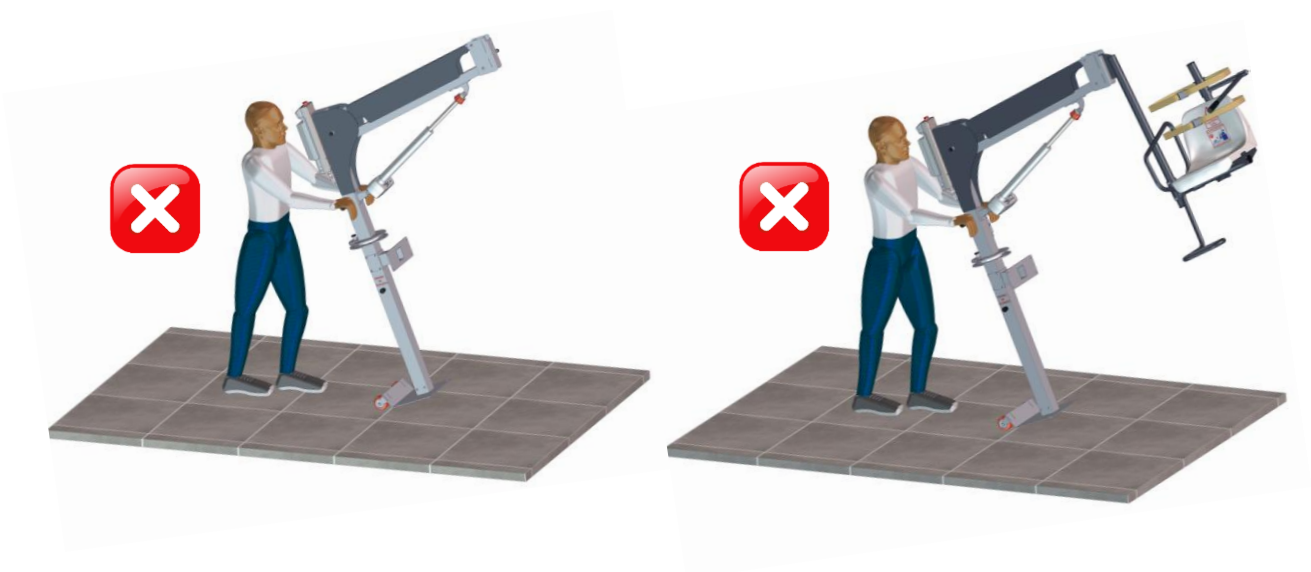

10 basic rules

1 METALU equipment must be installed in accordance with the manufacturer's instructions, making any necessary enquiries. The installer must test the equipment once installation has been completed and ensure that everything is functioning correctly.

2 In accordance with Article 12 of Law 11/1997 on Packaging, the final holder is responsible for the packaging. Reuse it whenever possible and dispose of the remainder at appropriate recycling facilities.
Protecting the environment is everyone's responsibility.



3 METALU equipment must only be used by facility managers and authorised users.

4 Facility managers must be familiar with the equipment after having read the instructions. If, after reading them, there are any doubts, the manufacturer must be contacted using the addresses provided therein.

5 Facility managers must inform users about the correct operation of the equipment.

6 Before operating the lift, ensure that the operating radius is clear. While the lift is in operation, do not place hands or any objects in its moving parts.



7 External cleaning is a mandatory condition for warranty validity. Follow the cleaning instructions supplied with the lift.



8 In accordance with the Low Voltage Electrical Regulations (REBT), ITC-BT-31, the machine must be connected to the equipotential bonding conductor that the swimming pool is required to have.

9 The installer must be aware of and take into account the regulations of the relevant autonomous community when carrying out the installation.

10 If the holder of this document is not the final customer, it must be passed on to them.

MANUFACTURAS METÁLICAS LUISIANERAS, S.L.

Battery-powered pool lift METALU S-3800 y S-3800/1

Installation

Address: Polígono Industrial Los Motillos, C/ Madrid No. 11, units A, C, D, G, H. 41430.

City: La Luisiana (Sevilla) – España.

Tax ID: B – 41834508

Main telephone: +34 955 907 784

Website: www.ascensoracuatico.com

Email: info@ascensoracuatico.com

Technical support contacts:

- Telephone: +34 613 165 661
- Email: soporte1@ascensoracuatico.com



Other documentation available:



Installation and assembly



Exploded view and
troubleshooting